

MAHESH TUTORIALS I.C.S.E.

ICSE X

SUBJECT : **BIOLOGY**

BOARD PAPER – 2014
QUESTION PAPER

SECTION - A (40 marks)

(Attempt all questions from this section)

Question 1

(a) Name the following :

- (i) The part of the brain associated with memory.
- (ii) The ear ossicle which is attached to the tympanum.
- (iii) The type of gene, which in the presence of a contrasting allele is not expressed.
- (iv) The hormone secreted by Islets of Langerhans.
- (v) The process of conversion of ADP into ATP during photosynthesis. [5]

(b) State the main function of the following :

- (i) Cerebrospinal fluid.
- (ii) Eustachian tube.
- (iii) Suspensory ligament of the eye.
- (iv) Sperm duct.
- (v) Lenticels. [5]

(c) Copy and complete the following by filling in the blanks 1 to 5 with appropriate words :

The human female gonads are ovaries. A maturing egg in the ovary is present in a sac of cells called.....(1). As the egg grows larger, the follicle enlarges and gets filled with a fluid and is now called the(2) follicle. The process of releasing the egg from the ovary is called(3). The ovum is picked up by the oviduct funnel and fertilization takes place in the(4). In about a week the blastocyst gets fixed in the endometrium of the uterus and this process is called.....(5). [5]

(d) Given below are six sets with four terms each. In each set one term is odd and cannot be grouped in the same category to which the other three belong. Identify the odd one in each set and name the category to which the remaining three belong. The first one has been done as an example.

Example : Calyx, Corolla, Stamens, Midrib
odd term : midrib
Category : Parts of a flower.

- (i) Haemoglobin, Glucagon, Iodopsin, Rhodopsin.
- (ii) Urethra, Uterus, Urinary bladder, Ureter.

- (iii) Transpiration, Photosynthesis, Phagocytosis, Guttation.
- (iv) Cyton, Photon, Axon, Dendron.
- (v) Oxytocin, Insulin, Prolactin, Progesterone.

[5]

- (e) **The figure given below represents an experimental set up with a weighing machine to demonstrate a particular process in plants. The experimental set up was placed in bright sunlight. Study the diagram and answer the following questions :**

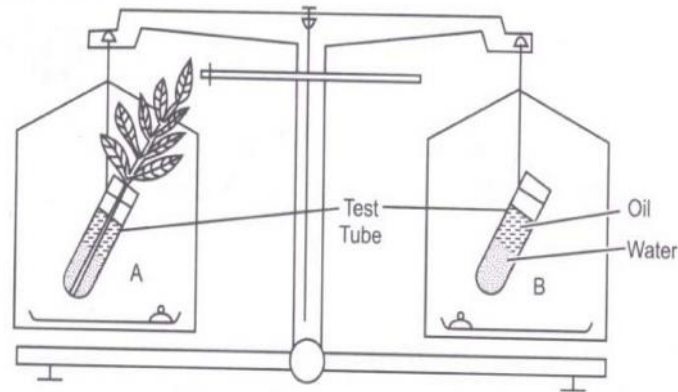

- (i) Name the process intended for study.
- (ii) Define the above mentioned process.
- (iii) When the weight of the test tube (A and B) is taken before and after the experiment, what is observed ? Give reasons to justify your observation in A and B.
- (iv) What is the purpose of keeping the test tube B in the experimental set up?

[5]

- (f) **Match the items given in Column A with the most appropriate ones in Column B and rewrite the correct matching pairs from Column A and Column B :**

Column A	Column B
(i) Pituitary gland	(a) Testosterone
(ii) Sulphur dioxide	(b) Calcium
(iii) Seminiferous tubules	(c) Growth hormone
(iv) Clotting of blood	(d) Acid rain
(v) Guttation	(e) Sperms
	(f) Global warming
	(g) Magnesium
	(h) Hydathodes

[5]

- (g) **Choose the correct answer from the options given below :**

- (i) Cretinism and Myxoedema are due to :
 - (a) Hypersecretion of thyroxin
 - (b) Hypersecretion of growth hormone.
 - (c) Hyposecretion of thyroxin.
 - (d) Hyposecretion of growth hormone.

- (ii) Which of the following is not a natural reflex action ?
- (a) Knee-jerk.
 - (b) Blinking of eyes due to strong light.
 - (c) Salivation at the sight of food.
 - (d) Sneezing when any irritant enters the nose.
- (iii) After mitotic cell division, a female human cell will have :
- (a) 44 + xx chromosomes.
 - (b) 44 + xy chromosomes.
 - (c) 22 + x chromosomes.
 - (d) 22 + y chromosomes.
- (iv) The antibiotic penicillin is obtained from :
- (a) Protozoan.
 - (b) Bacteria.
 - (c) Virus.
 - (d) Fungus.
- (v) The site of maturation of human sperms is the :
- (a) Seminiferous tubule.
 - (b) Interstitial cells
 - (c) Epididymis.
 - (d) Prostate gland.

[5]

(h) State the exact location of the following :

- (i) Tricuspid valve.
- (ii) Amnion.
- (iii) Yellow spot.
- (iv) Seminal vesicle
- (v) Adrenal gland.

[5]

SECTION - B (40 marks)

(Attempt any four questions from this section)

Question 2

(a) Differentiate between the following pairs on the basis of what is mentioned within brackets :

- (i) Spinal nerves and Cranial nerves (Number of nerves)
- (ii) Near vision and Distant Vision (Shape of the eye lens)
- (iii) Corpus callosum and Corpus luteum. (Function)
- (iv) Turgor pressure and Wall pressure. (Explain)
- (v) Disinfectant and Antiseptic (Defination)

(b) The diagram along side represents the simplified HEAD pathway of the circulation of blood. Study the same and answer the questions that follow :

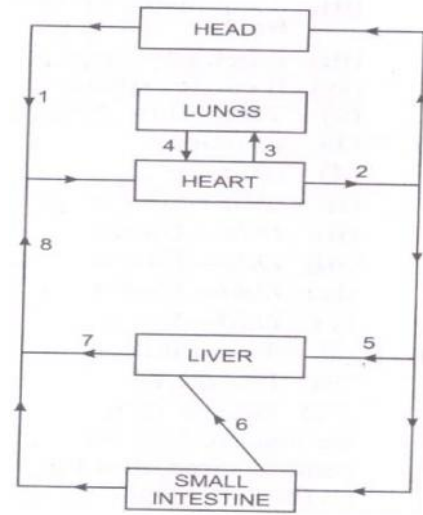

- (i) Name the blood vessels labelled 1 and 2.
- (ii) State the functions of blood vessels labelled 5 and 8.
- (iii) What is the importance of the blood vessel labelled 6 ?
- (iv) Which blood vessel will contain a high amount of glucose and amino acids after a meal ?
- (v) Draw a diagram of the different blood cells as seen in a smear of human blood.

[5]

Question 3

(a) A candidate in order to study the process of osmosis has taken 3 potato cubes and put them in 3 different beakers containing 3 different solutions. After 24 hours, in the first beaker the potato cube increased in size, in the second beaker the potato cube decreased in size and in the third beaker there was no change in the size of the potato cube. The following diagrams show the result of the same experiment :

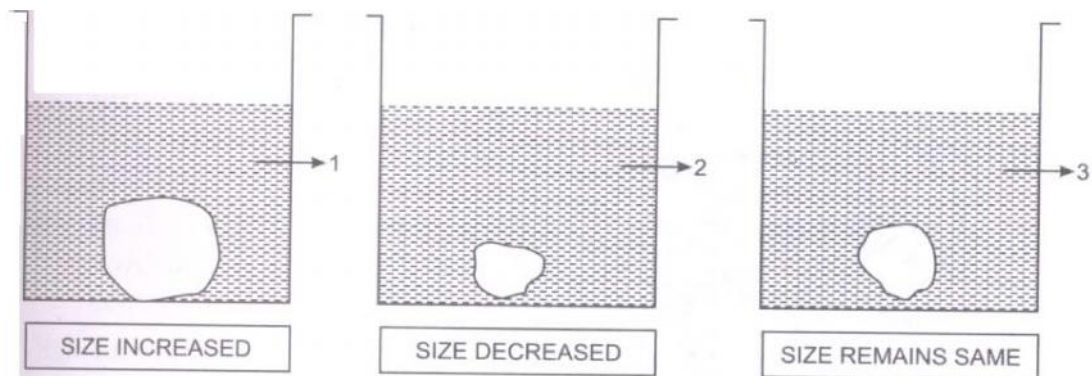

- (i) Give the technical terms of the solutions used in beakers, 1, 2 and 3.
- (ii) In beaker 3 the size of the potato cube remains the same. Explain the reason in brief.
- (iii) Write the specific feature of the cell sap of root hairs which helps in absorption of water.
- (iv) What is osmosis ?
- (v) How does a cell wall and a cell membrane differ in their permeability ? [5]

(b) A potted plant was taken in order to prove a factor necessary for photosynthesis. The potted plant was kept in the dark for 24 hours. One of leaves was covered with black paper in the centre. The potted plant was placed in sunlight for a few hours.

- (i) What aspect of photosynthesis was being tested ?
- (ii) Why was the plant placed in the dark before beginning the experiment ?
- (iii) During the starch test why was the leaf :
 - (1) boiled in water
 - (2) boiled in methylated spirit.
- (iv) Write a balanced chemical equation to represent the process of photosynthesis.
- (v) Draw a neat diagram of a chloroplast and label its parts. [5]

Question 4

(a) The diagram given below is a representation of a certain phenomenon pertaining to the nervous system. Study the diagram and answer the following questions :

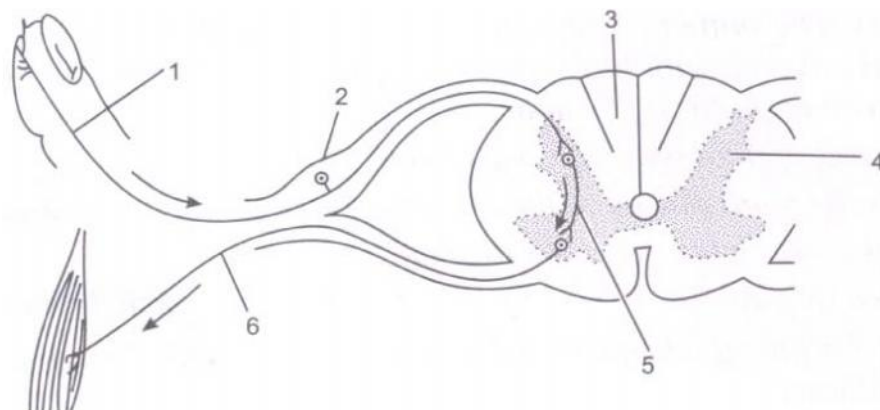

- (i) Name the phenomenon that is being depicted.
- (ii) Give the technical term for the point of contact between the two nerve cells.
- (iii) Write the functions of parts 5 and 6.
- (iv) How does the arrangement of neurons in the spinal cord differ from that of the brain ? [5]

(b) Give scientific reasons for the following statements :

- (i) Use of CFC is banned in many countries.
- (ii) We cannot distinguish colours in moonlight.
- (iii) Balsam plants wilt during midday even if the soil is well watered.
- (iv) Carbon monoxide is highly dangerous when inhaled.
- (v) A person after consuming alcohol walks clumsily. [5]

Question 5

(a) **Given below is a diagram representing a stage during mitotic cell division. Study it carefully and answer the questions that follow :**

- (i) Is it a plant cell or an animal cell ? Give a reason to support your answer.
- (ii) Identify the stage shown.
- (iii) Name the stage that follows the one shown here. How is that stage identified?
- (iv) How will you differentiate between mitosis and meiosis on the basis of the chromosome number in the daughter cells ?
- (v) Draw a duplicated chromosome and label its parts.

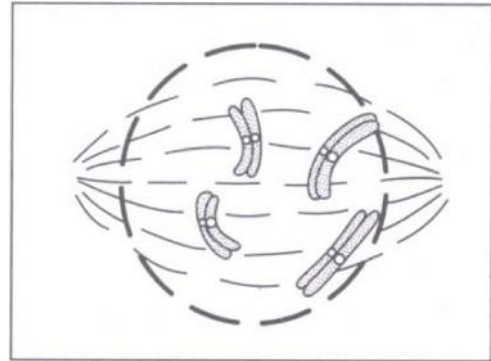

[5]

(b)

- (i) Name the disease for which following types of vaccines are given :
 - (1) Salk's Vaccine.
 - (2) B.C.G.
- (ii) Give one example of each of the following :
 - (1) A water pollutant.
 - (2) An aquatic plant used in the lab to demonstrate O₂ liberation during photosynthesis.
 - (3) An antibiotic.
 - (4) A nitrogenous base in DNA.
- (iii) Expand the following biological abbreviations :
 - (1) ATP (2) TSH (3) DPT (4) DNA

[5]

Question 6

(a) **The given diagram represents a nephron and its blood supply. Study the diagram and answer the following questions :**

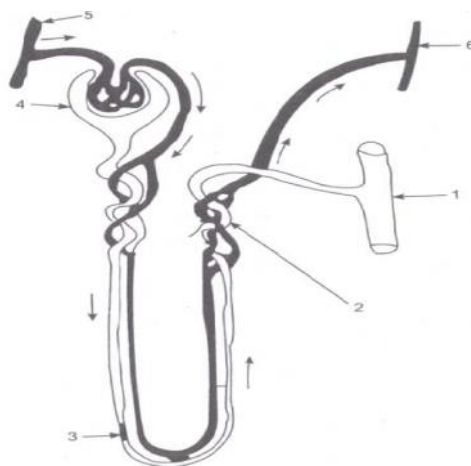

- (i) Label parts 1, 2, 3 and 4.
- (ii) State the reason for the high hydrostatic pressure in the glomerulus.
- (iii) Name the blood vessel which contains the least amount of urea in this diagram.
- (iv) Name the two main stages of urine formation.
- (v) Name the part of the nephron which lies in the renal medulla. **[5]**

(b) Briefly explain the following terms :

- (i) Monohybrid cross.
- (ii) Biomedical waste.
- (iii) Innate immunity.
- (iv) Diapedesis.
- (v) Hormones. **[5]**

Question 7.

(a)

- (i) State any two harmful effects of noise pollution on human health.
- (ii) Categorize the following activities as per the functions of the Red Cross Society and the WHO :
 - (1) To suggest quarantine measures to prevent spread of disease.
 - (2) Humanitarian services to victims of war.
 - (3) To educate people in accident prevention.
 - (4) To promote projects for research on disease.
- (iii) Write any two major reasons for the population explosion in India.
- (iv) State Mendel's Law of Segregation. **[5]**

(b) Give technical terms for the following :

- (i) A method of contraception in which the sperm duct is cut and ligated.
- (ii) Statistical study of human population.
- (iii) The protective covering of the heart.
- (iv) A sudden heritable change in the gene.
- (v) Repeated units of DNA molecule.
- (vi) The fluid portion of blood.
- (vii) The nerve that transmits impulses from the ear to the brain.
- (viii) Group of hormones which influence other endocrine glands to produce hormones.
- (ix) Thin walled sac of skin that covers the testes.
- (x) The permanent stoppage of the menstrual cycle in a woman aged 50 years. **[5]**

